

Review Article

A Review on Experimental, Numerical, and Machine Learning-based Solar Energy Harvesting for Road Pavements Application

Muhammad Imran Najeeb¹, Nurul Aqilah Razeman², Zarina Itam^{3,4*},
Salmia Beddu⁴, Nazirul Mubin Zahari⁴, Mohd Zakwan Ramli⁴,
Mohd Hafiz Zawawi⁴, Nur Liyana Mohd Kamal⁴, Agusril Syamsir^{3,4}
and Daud Mohamad⁴

¹Department of Engineering Education, Faculty of Engineering and Built Environment, Universiti Kebangsaan Malaysia, 43600 Bangi, Selangor, Malaysia

²College of Graduate School, Universiti Tenaga Nasional, Jalan IKRAM - UNITEN, 43000 Kajang, Selangor, Malaysia

³Institute of Energy Infrastructure, College of Engineering, Universiti Tenaga Nasional, Jalan IKRAM - UNITEN, 43000 Kajang, Selangor, Malaysia

⁴Civil Engineering Department, College of Engineering, Universiti Tenaga Nasional, Jalan IKRAM - UNITEN, 43000 Kajang, Selangor, Malaysia

ABSTRACT

Revolutionizing solar energy utilization through solar pavement technology offers a path to sustainable infrastructure and reduced greenhouse emissions. This review article synthesizes findings from experimental, numerical and machine learning-based studies to optimize solar energy harvesting in pavement applications. The experimental and numerical analyses focus on achieving optimal thermal efficiency and maximizing the outlet pipe's temperature in Pavement Solar Collectors (PSC) through

detailed parametric studies. Machine learning tools are then employed to further enhance PSC performance by integrating additional input parameters, varied PSC designs, and diverse environmental conditions. Key insights from this review indicate that integrating machine learning into PSC design significantly broadens the scope and efficiency of these technologies, positioning solar pavement as a viable approach to reducing greenhouse gas emissions. Future works from this technology include looking into a multi-functional renewable energy system that produces hydrogen powered by solar power.

ARTICLE INFO

Article history:

Received: 15 July 2024

Accepted: 24 December 2024

Published: 26 March 2025

DOI: <https://doi.org/10.47836/pjst.33.3.05>

E-mail addresses:

imran.najeeb@ukm.edu.my (Muhammad Imran Najeeb)

aqilahrazeman@gmail.com (Nurul Aqilah Razeman)

izarina@uniten.edu.my (Zarina Itam)

salmia@uniten.edu.my (Salmia Beddu)

nazirul@uniten.edu.my (Nazirul Mubin Zahari)

zakwan@uniten.edu.my (Mohd Zakwan Ramli)

mhafiz@uniten.edu.my (Mohd Hafiz Zawawi)

yana_kamal@uniten.edu.my (Nur Liyana Mohd Kamal)

agusril@uniten.edu.my (Agusril Syamsir)

daud@uniten.edu.my (Daud Mohamad)

* Corresponding author

Additionally, the adaptability of these developed models suggests potential applications in solar collectors for roof tiles, building walls, and related energy-efficient systems.

Keywords: Asphalt, heat exchange, machine learning, solar energy, solar pavement collector

INTRODUCTION

Over the past hundred years, the world has heavily relied on oil and fossil fuels to generate power. This source of energy is not renewable, and the by-products produced from power generation, such as greenhouse gases, cause the average temperature to rise (Yoro & Daramola, 2020). This indirectly contributes to global warming by increasing carbon dioxide emissions, causing detrimental effects on the environment, such as disrupting the existing ecosystem, rising ocean temperatures, increasing sea water levels, and many more (Bhan et al., 2020). The surge in the global population and the relentless march of globalization are contributing to an escalating demand for energy and heightened consumption levels. As a result, the world's reliance on non-renewable energy sources leads to the rapid depletion of fossil fuel reserves. Primc et al. (2021) identified several key issues associated with non-renewable dependencies, such as the complexity of power lines management, lack of local substations, and outdated monitoring technologies, leading to increased electricity costs. Hence, identifying viable renewable energy sources is essential to meet energy demand while preserving natural resources. Desired features of alternative renewable energy sources include those that are naturally replenished, such as solar, hydropower, wind, geothermal, bioenergy, and ocean energy (Owusu & Asumadu-Sarkodie, 2016).

Renewable resources have gained popularity as effective energy source substitutes to overcome power shortages, halt continuous environmental degradation, and meet future global energy demands (Esposito & Romagnoli, 2023). Extensive studies conducted on renewable energy as an alternative energy source show promising potential in the future compared to fossil energy, driven by the United Nations Sustainable Development Goal (SDG 7) for affordable and clean energy. As depicted in Figure 1(a), pertinent literature was gathered from the Web of Science Master Journal List utilizing specific keywords that include “solar energy,” “hydropower,” “wind energy,” “geothermal energy,” “bioenergy,” and “ocean energy.” Subsequently, the refine tab was applied for the last ten years. Solar energy is among the renewable resources that have emerged as a leading sector with considerable global research and development. Notably, the top-performing countries in solar energy research are also pioneering advanced solar technologies, as Figure 1(b) highlights.

The introduction of solar energy technology has significant future market potential due to its cleanliness and abundant availability (Hayat et al., 2019). There were two ways of generating solar electricity: solar-photovoltaic (PV) cells and concentrating solar power

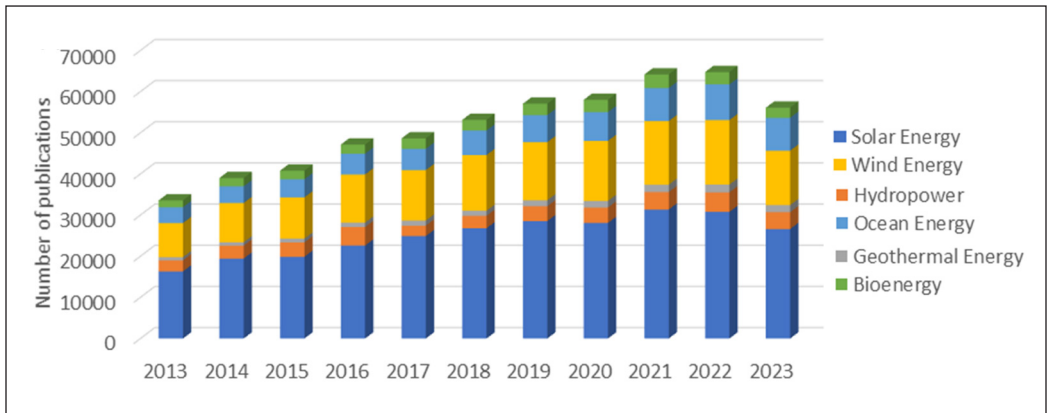

(a)

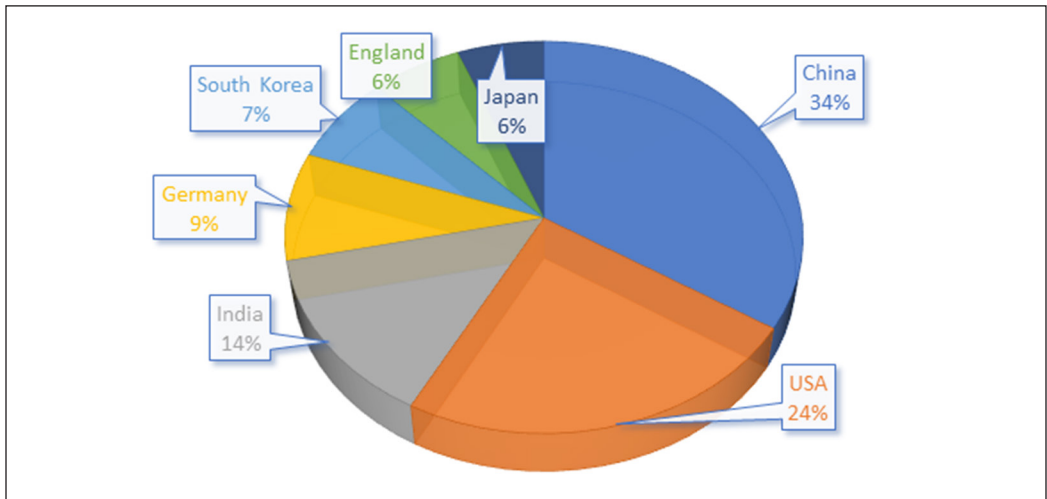

(b)

Figure 1. (a) Studies on renewable energy field; and (b) Top seven countries leading in research and development in renewable energy field for the past decade

(CSP) technologies. Recent developments in solar PV cell technology show improvements in terms of efficiency, up to 34.1%, shown by multi-junction (MJ) photovoltaic cells. A diverse array of companies has embraced solar energy technologies as an alternative energy source. Besides, the technology is now available at reasonable prices. The energy generated from this source was used for heating, cooling, and outdoor and indoor lighting, as CSP uses linear cavity receivers, which minimize the heat escape (Kalidasan et al., 2023). Several factors affected the receivers' thermal performance, such as the cavity geometry, thermal emissivity, fluid temperature, and wind direction (Garg & Saini, 2018). Besides, studies have been conducted to utilize solar energy in drying technologies for food preservation, known as solar dryers. The solar dryers' performance was enhanced by integrating with

phase change materials (PCMs) and other heat storage systems to improve drying kinetics and efficiency (Tyagi et al., 2024). Moreover, the PCMs can also be used to enhance thermal energy storage in diverse solar thermal systems, emphasizing low, medium, and high-temperature applications (Kalidasan et al., 2020).

Another method to attain sustainable development using renewable energy sources is by utilizing surface solar radiation. Surface solar radiation is the amount of sunlight energy reaching the Earth's surface, which influences the surrounding environment, including solar power production. Yang et al. (2018) concluded that the thermodynamic and dynamic state of the Earth's atmospheric systems are important signals that reflect climate change. Researchers globally have studied solar radiation variations and other factors affecting it using observed data. Since solar radiation is gaining importance as an energy source on the Earth's surface, research on utilizing solar radiation as a renewable energy source is essential. The optimal approach for tapping into solar energy and radiation without constructing additional infrastructure, such as solar farms, involves integrating solar technologies into existing structures, like road pavements. For instance, Saudi Arabia recorded over 73,000 km of paved roads in 2019, illustrating the vast potential this region holds for future opportunities since they had a high average mean surface temperature recorded between 16°C and 33°C yearly (Statista, 2021; The World Bank Group, 2021). A typical road pavement solar collector typically includes pipes with a circulating liquid within the pipes, as shown in Figure 2.

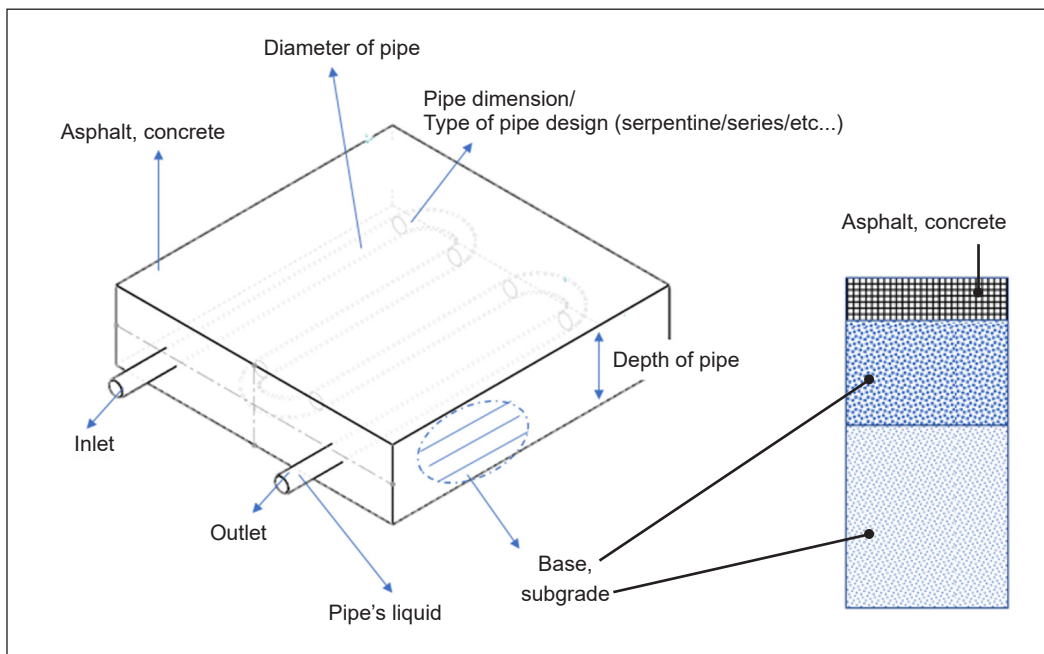

Figure 2. A general view of pavement solar collector components

This review is significant as it consolidates the latest breakthroughs in solar pavement technology, emphasizing the role of experimental, numerical, and machine-learning methodologies in enhancing efficiency and application. This research offers a comprehensive evaluation of solar pavement technology, integrating diverse techniques, in contrast to other studies focusing on isolated features like thermal efficiency or specific material performance. This paper identifies significant improvements in experimental discoveries, design optimizations, and machine learning applications that have not been thoroughly explored in a single review previously. This review is innovative due to its comprehensive approach, examining existing limits and upcoming prospects to improve solar energy capture in pavement applications. This contribution aims to give researchers and industry practitioners a strategic framework, emphasizing possible effects on urban energy systems, sustainable infrastructure, and environmental advantages, including reductions in greenhouse gas emissions. Furthermore, the results are anticipated to broaden the domain of solar pavement research, providing a basis for additional investigations and applications in diverse structures, including roof tiles and building walls, beyond conventional pavement settings.

SOLAR ENERGY HARVESTING PRINCIPLE AND ITS APPLICATIONS

Solar energy transforms a significant amount of radiant energy into heat, which is then harnessed for various applications. This approach is one of the most widely employed methods for harnessing solar energy. It has reached an advanced stage of industrialization, is characterized by its simplicity of implementation, and holds the greatest promise to eventually supplant conventional strategies and technologies reliant on fossil fuels. Gong et al. (2019) studied the approach of solar energy conversion for electricity or thermal power generation by utilizing photovoltaics or photothermal transduction agents (PTAs). Research on both inorganic and organic hybrid perovskites showed notable enhancements in photovoltaic efficiency as well as device stability.

The solar technology category depends on the methods employed for capturing, converting, and distributing solar energy, primarily falling into two distinct categories: passive solar and active solar energy systems (Kabir et al., 2018). The thermoelectric effect of active solar technology is an actual occurrence that turns a temperature differential into voltage via a thermocouple. One fundamental phenomenon underlying this effect is the Seebeck Effect, which occurs when an electric voltage is generated across two different conductive materials due to a temperature gradient. For instance, thermoelectric generators utilize the Seebeck Effect to convert waste heat into electricity, commonly found in power plants (Gonçalves et al., 2020). The Seebeck Effect occurs when two types of semiconductors, P-type and N-type, are chemically combined, forming a p-n junction and generating electromotive force (Kim et al., 2017). Carriers (conductors and semiconductors), along with passive and active

materials, move in response to a temperature gradient to complete the transformation from solar thermal to electrical energy (Kabir et al., 2018).

Moving on to renewable energy perspectives, solar energy enables the direct conversion of solar energy to electricity with rapid and easy grid connection despite the restricted power generation. During the day, photovoltaics provide renewable energy to the grid. Additionally, the power generated during the day can be stored in batteries or supercapacitors and later used to meet a portion of the electrical demand at night (Carrasco et al., 2006).

The benefits of solar energy in the new energy system include diverse sources, no pollution, and abundant energy (Ferreira et al., 2020). Additional studies confirm that solar energy technologies have been proven to reduce carbon emissions, which were previously sourced from fossil fuels for electricity. This allows for the powering of signage and lighting in remote areas, resulting in improved safety for road users. Solar radiation absorbs significant heat from the pavement, allowing for its collection. A study developed a cutting-edge thermoelectric generator system capable of transforming the heat differential between the road surface and the soil underneath into electrical energy and producing 29 milliwatts of electrical energy on average (Johnsson & Adl-Zarrabi, 2020).

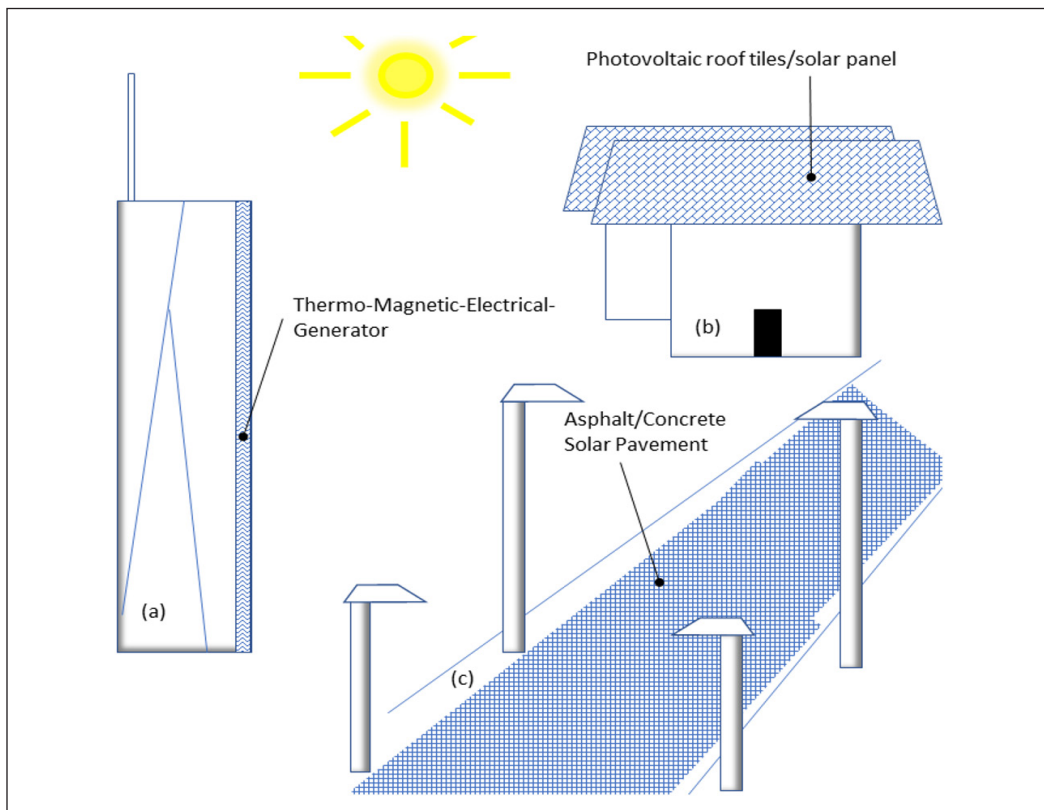

Figure 3. Renewable energy system: (a) Wall building; (b) roof; and (c) road pavement

Interest has shifted toward the integration of photovoltaic cell technology into civil-building structures such as roof tiles, walls, and road pavement, as shown in Figure 3. However, the conversion efficiency of photovoltaic cells is temperature-dependent, where high temperatures can cause a reduction in efficiency. Alim et al. (2020) found that to regulate the temperature of the solar cells, it is essential to integrate them with phase change material (PCM) into the mortar roof tiles. For this integration, the tile was added with a concentration of 3% by weight of PCM, which shows 4.1% more electrical output compared to without PCM filler. The PCM properties were able to absorb and release thermal energy efficiently.

A study on an Indian smart city concept by Saha and Frøyen (2021) shows that the main part of a smart city is the need to continuously produce and supply electricity to sustain the city, as they heavily rely on technologies powered by electricity. Therefore, it is important to utilize each part and area of the city to harness solar energy. Several cities have achieved success in becoming a national benchmark for large-scale adoption of solar energy in their cities. For example, Diu Smart City in India and Trondheim in Norway utilize renewable solar energy during the daytime, setting a benchmark for other local cities to follow and implement the technology. Another solar application capable of transforming sunlight on wall surfaces into heat energy is the installation of a thermo-magnetic-electrical-generator (TMEG) on building surfaces. The TMEG units are fixed between two wall layers with varying temperatures (hot and cold walls). This is made possible through the use of Gadolinium (Gd) as the ferromagnetic material due to its convenient Curie point, allowing it to move in a space between two zones with varying temperatures (Homadi et al., 2020).

Next are the solar collectors for asphalt or concrete pavement applications. Pipes containing water or other fluids were incorporated beneath the pavement layers, functioning to accumulate heat, which would later be harvested for energy (Todd, 2011). Kehagia et al. (2019) outlined two different types of solar pavements: thermal collectors and electrical collectors. These were examples of sophisticated structures that can contribute to long-term road infrastructure sustainability. Incorporating innovative technology into asphalt pavements has demonstrated the viability of harnessing solar energy. Solar pavement collectors (PSC) are used to fulfill the urban environment's thermal and electrical demands. The thermal collection process starts with the accumulation of heat from the sun. This warmth is captured by the water running through the network of pipes buried in the lane's surface layer, enabling continuous heat collection on hot summer days and supplying on-site renewable energy. Heat moves from a hotter location to a cooler side, either from the pavement to the water in the piping system or the other way around. These help regulate the pavement temperature during the summer and winter (Kehagia et al., 2019). For instance, a Dutch company, Ooms Avenhorn Holding, used PSC technology to gather solar energy from asphalt roadways during the summer and use it during the winter to

warm the apartment buildings and Dutch Air Force runways. Furthermore, implementing road energy systems can quickly cool hot roads during the summer and prevent rapid deterioration (Xu et al., 2021).

The design of PSCs was observed to offer ample opportunities for upgrades aimed at enhancing their efficiency, such as modifying the albedo, fluid flow rate, and pipe spacing (Johnsson & Adl-Zarrabi, 2020). Guldentops et al. (2016) conducted research that evaluated the effect of the integrated pipe's design on the PSC's thermodynamics and efficiency using experiments and numerical analysis. The pipe design and configuration influence the thermal efficiency up to 70% (Guldentops et al., 2016). On the other hand, the performance of the PSC is affected by its region of usage. For example, an urban street canyon equipped with a PSC system shows, on average, 36.08% more thermal collection with a 27.11% surface temperature reduction compared to the PSC application in a rural area (Nasir et al., 2015). The PSC systems are suitable for sustainable city projects since they serve as a dual-function system that reduces the ground surface temperature and is a tool for harnessing heat energy. van Bijsterveld et al. (2001) conducted a thermal analysis using a finite element module for materials science and structural engineering (FEMMASSE), a finite element program. The input data were collected from a site test located in the northern Netherlands that employed polyethylene tubes on the main road to regulate the pavement temperature. The developed finite element modeling shows there were high stresses and strains forming around the tubes (van Bijsterveld et al., 2001). With this discovery, it is also important to note the effect of the structure of the PSC system in the long run due to the heat exchange process, which could impact the integrity of the road structure. Dezfooli et al. (2017) found that when using solar pavements as a renewable energy producer to generate voltage compared to solar panels, solar pavements have the capacity to enhance the rutting performance for transportation applications. The components used in the assembly of the solar pavement include rubber tubes, steel pipes, and serpentine copper. Researchers evaluated the design of these pavements based on energy supply, surface safety movements, and structural performance. The suitable efficiency of solar pavements was also measured based on structural resistance and skid resistance.

Solar pavement technology must demonstrate to future users that it makes economic sense to change their current installations or integrate them into new installations or retrofits. The method considered by Ryms et al. (2017) was to replace the asphalt or concrete pavement with an electronic layer structure comprising a multi-layer system between the base solar collectors and the wearing courses. The wearing course will be translucent, allowing sunlight to reach through the collection sheet. The sun powers the electrical core, enabling it to flash signals and produce energy for motorists to replace signs and markings. Beddu et al. (2016) studied the use of hot surface energy in electricity production and the concurrent reduction in pavement temperature during the season. Researchers tested the

heat exchange rate and temperature effect through measurement and modeling (Beddu et al., 2016). The thermally transmitted fluid has a direct effect on peak power output, and thermoelectric modules resist it. According to the authors, the surrounding weather and fluid temperature mostly affect the efficiency of heat transfer.

According to the literature, research on solar collector technologies has predominantly focused on analyzing the thermal characteristics of road pavement compared to roof tiles and wall buildings. This underscores the pressing need for sustainable development, emphasizing the pivotal role of promoting solar energy as a renewable source for future energy needs.

THE PAVEMENT SOLAR COLLECTOR

Solar radiation exposure, pavement materials, and innovative design create an ideal environment for harnessing solar energy on a large scale. Xu et al. (2021) proposed replacing regular roadways with photovoltaic solar panels, known as “Solar Roadways”. Asphalt pavement solar heat collectors have been proven to be highly effective in practical applications worldwide. In real-life applications, a few parameters need to be taken into account to evaluate the heat harnessing efficiency, such as the slope gradient, slope exposure, and orientation of the streets and open spaces (Finn et al., 2021). Therefore, various simplifications are necessary for performing heat transfer simulations due to the complex structure of solar panel pavement conversion (Vinod et al., 2018). On top of that, the solar panel pavement is a multi-layered structure composed of homogeneous and isotropic layers. Sunlight absorbed by the solar panel that is not converted to electricity is considered to be converted to heat. Dust and any other discharged substances on the photovoltaic pavement surface that have an effect on the solar panel’s absorptivity would be overlooked due to their minor influence. Meanwhile, because the sides of a solar panel are so tiny in comparison to the top and bottom faces, the energy lost via the sides is ignored (Ma et al., 2019). Figure 3 illustrates the thickness layers of asphalt/concrete (AC) pavements. The life cycle assessment (LCA) showed the utilization of solar pavements for long-term environmental benefits, even though the economic cost was higher than conventional concrete and asphalt pavements (Hu et al., 2023). Hence, a few parameters need to be considered for the pavement solar collectors’ efficiency.

DESIGN AND MATERIAL CONSIDERATIONS FOR PIPES IN PSC SYSTEMS

Asphalt pavements absorb a large quantity of thermal energy from solar radiation throughout the day. The Pavement Solar Collectors (PSC) represent a method of harvesting solar energy and converting it to thermal energy. Zaim et al. (2020) found that PSCs comprise a series of metal or non-metal pipes (like copper, rubber, stainless steel, and polyethylene pipes)

buried in paving slabs. A moving fluid inside the PSCs collects heat from the hot pavements (Zaim et al., 2020). There were several pipe designs being studied, including serpentine, series, ladder configuration, balanced-ladder configuration, and parallel.

Pipe Design

An experiment conducted by Zaim et al. (2020) placed a steel pipe at a depth of 300 mm below the top surface of the PSC. Stainless steel pipes in a series configuration filled with water were placed at the center of the PSC (Zaim et al., 2020). The pipe's internal diameter is 15.8 mm, and the pipes were arranged consistently with roughly 110 mm center-to-center spacing. The experiments were conducted in Bam, Iran, and monitored through both the summer and winter seasons. The experimental setup determined the peak output temperature, the temperature disparity, and the pressure loss of the pipes. Results show that the experimental design parameters have a considerable impact on the PSC's characteristics and functionality. Furthermore, the authors developed and evaluated four pipe configurations using simulation analysis under the same conditions as mentioned above to determine the effect of pipe arrangement on PSC performances. Four distinct pipe configurations were explored, each with general and specific technological characteristics. These configurations were categorized based on the fluid flow pattern within the PSC. The illustration of the pipe configurations is presented in Figure 4. The result shows that the serpentine configuration resulted in a greater distance covered by the flowing water than the other three configurations. Experimental results also show that the fluid flow rate is constant along the circulation route for the serpentine configuration, while the intake fluid flow is segmented into several channels for the other configurations.

The intake and outlet temperatures are the other critical components affecting a pavement solar collector's performance. The serpentine pipe configuration shows greater temperature differences compared to the other configurations. Zaim et al. (2020) further discussed that the water traveling distances and the temperature differences obtained in the balanced-ladder (d) and parallel (b) arrangements are close to each

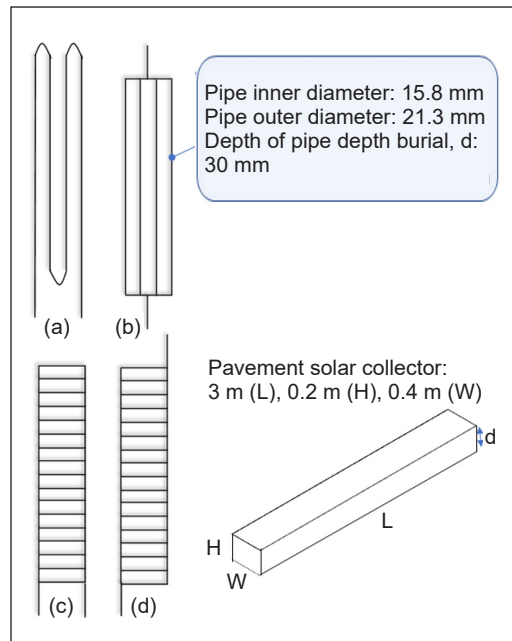

Figure 4. Pipe dimension and configuration: (a) Serpentine; (b) parallel; (c) ladder; and (d) balanced ladder

other. As for the ladder configuration (c), the circulating water goes just the shortest distance within the pipe, showing that it is not a good configuration as it does not cover all the pavement areas.

In different studies, Zhou, Pei, Hughes et al. (2021) recommended separating the asphalt slab into two sections: side A (the water inlet) and side B (the water outlet). Thermocouples (K-type) monitored the temperature at three pavement depths: top, middle, and bottom. The results show that the heat on pipes has a substantial effect on the mechanical response, thermal reaction, and coupling response of the pavement structure. The heat pipe's surrounding structure, particularly at the bending zone, is the weakest part of the total pavement structure. The serpentine heat pipe greatly reduced the maximum bottom tensile stress. It is reasonable to conclude that the heat pipe can help prevent cracking in asphalt pavements. On the other hand, the idea of the pavement-integrated photovoltaic thermal system (PIPVT) is based on the building-integrated photovoltaic thermal system (BIPVT), which combines the study of PV pavement and thermal energy harvesting pavement. This integral aids in the recovery of the solar cells from severe solar heating and reduces the operating temperature of the solar cells (Zhou, Pei, Nasir et al., 2021).

Besides the shape of the pipe, the pavement materials themselves influence the heat exchange efficiency between the pavement and the pipe. A study showed that using conductive asphalt improved the solar extraction energy from the pavement to the pipe. A study shows that using conductive material, conductive hot-mix asphalt (limestone aggregates + silica sand + slag filler in place of limestone filler + 4% steel wool fibers) improved 20.94% thermal efficacy compared to normal hot-mix asphalt (all aggregates comprised limestone) (Abbas & Alhamdo, 2024).

Although the study of the pipe design provides robust data, more investigation is needed to examine how the various layouts affect pavement maintenance and longevity over a long period. Furthermore, the tribology effects on the PSC system and lifetime should be considered to guarantee its feasibility from various points of view.

Polyethylene Pipes

Polyethylene pipes in the upper layers of the pavement circulate fluid in a pavement solar collector (PSC). The pavement surface heats due to heat absorption from solar radiation, which is then transferred to the circulating fluid. Research conducted by Johnsson and Adl-Zarrabi (2020) found that modifying the albedo, fluid flow rate, and pipe spacing has an impact on the PSC's performance. The authors discovered that by adjusting the albedo and flow rate of the fluid, efficiency increased to 49%. However, when pipes are positioned closely, they present extra limitations. It is important to avoid excessively small bending radii for pipes to prevent damage. Additionally, if multiple pipes are placed in the pavement, the pavement's load-bearing capability will be affected. In general, a deeper position

and closer spacing between pipes result in a greater amount of generated electricity. The harvested energy has been measured at 245 kWh/m², boasting a solar efficiency of 42%.

Rubber and Copper Pipe

Apart from the polyethylene material, copper and rubber pipe were also used for investigation at the maximum outlet temperature. A study on serpentine copper and rubber pipes by Ahmad et al. (2018) proved that sustainable energy production by utilizing pavement surfaces as heat collectors is feasible. Henceforth, the calculation of solar efficiency under the paved surface using the finite element approach is needed. Serpentine, copper, and rubber pipes were employed in asphalt pavement. ANSYS software was used to prepare a model of asphalt pavement with dimensions of 300 mm x 500 mm. The asphalt surface is embedded with 40-mm-diameter serpentine copper and rubber pipes. Solar heat is gathered at 50-, 100-, and 150-mm depths in asphalt pavement. Coordinates are generated to locate the fluid flow in the pipes at the inlet and outlet. The meshing process of the two regions has been established, where one represents the link between pipes and asphalt pavement, and the second is between pipes and fluid flow in pipes. The results show that the maximum outlet temperature for rubber pipes was less than 12.63% compared to copper pipe at a 50-mm depth. Besides ANSYS, transient system simulation software (TRNSYS) has also been used to investigate the PSC efficiency of using a copper serpentine pipe through the evaluation of the temperature differential between the input and output of the pipe (Al-Manea et al., 2022). Table 1 summarizes the pavement and pipe material.

Table 1
Summary of pavements and pipe material for specific environmental conditions and practical application

Material	Properties	Practical application
Conductive asphalt	High thermal conductivity; durable under various temperature	Regions with high-temperature fluctuations (e.g., hot summers and cold winters)
Polyethylene (PE)	High corrosion resistance, impact and pressure	Suitable for air with high water pressure
Copper	Good thermal conductivity, corrosion resistance, easy to joints	Ideal for humid environment
Rubber	High flexibility, thermal insulation, and abrasion resistance.	High traffic zone

TYPES OF PIPE'S LIQUID AND ITS EFFICIENCY

Fluid flows through pipes to store heat energy. The rate of fluid flow has an effect on the amount of energy gathered. According to Johnsson and Adl-Zarrabi's (2020) research, increasing the fluid flow rate decreases the average fluid temperature, thereby improving heat transfer. If the flow rate is exceedingly low, the Pavement Solar Collector (PSC) will perform

inefficiently because of the small temperature difference between the fluids and the pavement layer. An increased fluid flow rate decreases the mean pavement temperature (Johnsson & Adl-Zarrabi, 2020). Therefore, the study revealed that increasing the fluid flow rate from 0.02 L/s to 0.17 L/s resulted in a rise in captured energy from 140 kWh/m² to 280 kWh/m².

Besides the fluid flow rate, the physical and thermal properties of the fluid, including density, specific heat capacity, and thermal conductivity, were important in investigating their influences on heat transfer in the PSC system. Additionally, compressibility and viscosity are important properties of a fluid from the standpoint of fluid mechanics (Nakayama, 2018).

Water

Water is a common fluid that is accessible, low-cost, and used in solar-collecting pipes. Cycled water in pipe systems collects heat energy and carries the extracted energy out of pavement solar collectors (Zaim et al., 2020). Therefore, an accurate calculation of the circulating water temperature is critical for analyzing the PSC's performance. Water was pumped at a constant rate and ejected at atmospheric pressure. Many distinct kinds of velocity initial conditions are employed at the pipe set's inlet and outlet portions, including intake velocity and outflow. As a result, the temperature of the water that has been stored within the storage tank began to rise in direct proportion to the flow rate of the returning water. The collector discharges water from the storage tank's bottom side to reduce heat dissipation. Based on research, the temperature records from the data logger and thermocouples revealed a notable difference between the initial and final temperatures at various slab depths and sides.

On the other hand, Zhou, Pei, Hughes et al. (2021) found that after 60 minutes of adding water to the asphalt slab, the surface temperature dropped from 80.6°C to 71.9°C. This also suggests that the heat pipe's circulating water has lowered the asphalt's surface temperature by 10.8%, which, by increasing the flow rate of the water, the efficiency of the pipes (Zhou, Pei, Hughes et al., 2021). However, Nasir et al. (2015) highlighted that increasing the flow rate of water does not reduce the pavement temperature significantly. Additionally, a comparable study discovered that changing the pipe's depth to 25 mm from 125 mm reduced the pavement temperature by 30%. Research has discovered that altering the temperature of the inlet water has the highest impact on the PSC system efficiency compared to the other parameters, such as water flow rate, solar radiation, and sun heat, as shown by a sensitivity analysis (Ahmadi et al., 2020).

Coolant (A Cooling Fluid)

The Pavement Integrated Photovoltaic Thermal System (PIPVT) absorbs solar energy and converts it to electricity. It also harvests some of the absorbed heat as thermal energy

using coolant circulated beneath the solar cells through serpentine copper pipes. The system increases solar energy utilization efficiency and can concurrently meet the power and thermal energy needs of households along the path.

Ethylene Glycol

Talib et al. (2017) conducted field tests on solar pavement under actual atmospheric conditions. The test consisted of asphalt pavement, an exchanger with a heat tube filled with ethylene glycol, solar heat, thermocouples, and data logging systems. The test set-up included empty steel pipes and steel pipes filled with ethylene glycol. At a depth of 150mm, ethylene glycol collected the highest amount of heat at 51.2°C. Over three days, the pipe temperature increased by 71% at a depth of 50mm, 78% at 100mm, and 62% at 150mm when using ethylene glycol. In comparison to a pipe without ethylene glycol, the impact of ethylene glycol was more apparent, and the pipe could hold additional heat.

Recommendation

Based on the findings, the optimum pipe design for pavement solar collectors is to have a pipe depth of around 50mm, pipe spacing of roughly 110mm and a fluid flow rate of 0.17L/s. The additional recommendation is to have a serpentine pipe configuration and conductive asphalt for pavement material. Table 2 shows the justification for the optimum configuration for the solar pavement collector.

Table 2
Summary of optimal pavement solar collector

Parameter	Optimal value	Justification
Pipe depth	50 mm	Balances heat absorption with pavement structural integrity
Pipe spacing	110 mm center-to-center	Ensure efficient heat collection and consistent flow distribution
Flow rate	0.17L/s	Improve energy efficiency
Pipe configuration	Serpentine	Optimal temperature difference and fluid flow reduce pavement cracking
Pavement material	Conductive asphalt	Improve thermal flow across the pavement

MACHINE LEARNING-BASED (ML)

The emergence of machine learning (ML) brings huge add-ons through more detailed parametric studies, especially for experimental and numerical modeling, to save time and high computational costs. There were many ML algorithms available either as open source or by subscription. ML includes gated recurrent units (GRU), artificial neural networks (ANN), Bayesian structural time series modules (BSTS), autoencoder networks,

feedforward neural networks (FFNN), long short-term memory (LSTM), convolutional neural networks (CNN), bidirectional long short-term memory (Bi-LSTM), Bayesian neural network module (BNN), least squares support vector machines (LSSVM), and adaptive neuro-fuzzy inference system (ANFIS) as shown in Figure 5 (Milad et al., 2021).

A study using ANN expanded the parametric studies by inputting the asphalt solar collector (ASC) system parameters, which were the thermal conductivity and surface absorptivity of asphalt, inlet water temperature, the water flow rate, solar irradiance, and time of day in the cold and warm months of November and August, investigating the outlet water temperature. The temperature difference between inlet and outlet water is 24 °C, with 45% thermal efficiency in August. Meanwhile, the temperature difference in November is 14 °C, with 35% thermal efficiency (Masoumi et al., 2020). Besides conducting parametric studies, the ANN model is also used in prediction investigations. In a study using an ANN

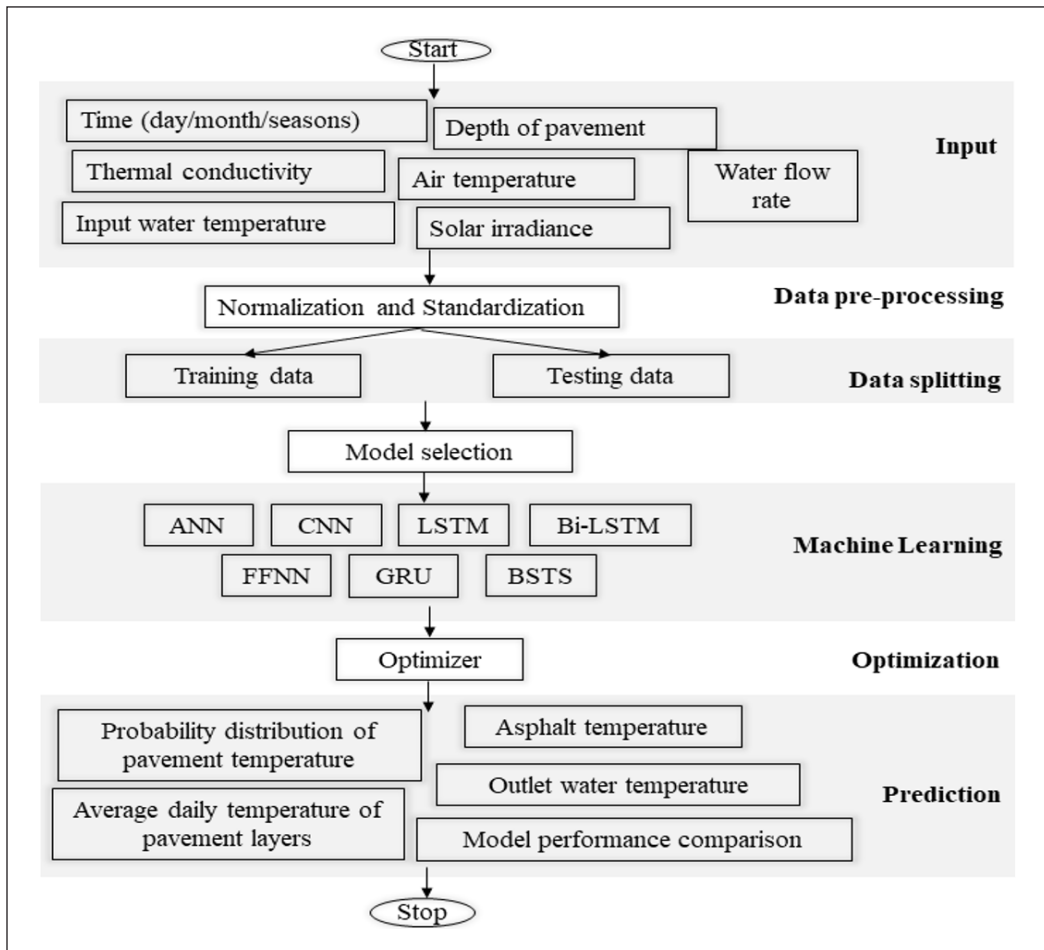

Figure 5. Machine learning model flowchart summary from literature

algorithm to predict the ASC layer temperature, The determination of the ASC layer under the influence of temperature is important for understanding its structural capacity due to its viscoelastic behavior (Nojumi et al., 2022). Therefore, prediction accuracy is required based on the input parameters (Abo-Hashema, 2013).

Another study used three different machine learning models to create a prediction model for ASC temperature using the autoencoder networks FFNN and LSTM. The algorithms show that the applied machine learning achieved accurate predictions, where the temperature was recorded between 2.80°C and 0.51°C for the mean absolute error (MAE). The autoencoder network model demonstrates the highest accuracy in predicting asphalt temperatures, followed by the FFNN and LSTM models. These studies also demonstrated that having additional input parameters such as wind speed and relative humidity enhanced the machine learning models significantly (Ghalandari, Shi et al., 2023). Besides predicting the asphalt pavement temperature, ML can also be used to predict the pavement's base and subgrade layer temperatures. A study developed a new ML approach using air temperature and number of days to predict the average daily temperature at the base and subgrade layers (Huang et al., 2023). Researchers used air temperature and pavement depth (0, 2, 5.5, and 7 cm) data for asphalt across different seasons (winter, summer, spring, and autumn) from the entire Gaza Strip between March 2012 and February 2013. The parameters were used as input in four types of ML, which were CNN, LSTM, Bi-LSTM, and GRU, to predict asphalt pavement temperature (APT) based on the input parameters (air temperature, depth, and seasons). The result of Bi-LSTM shows a robust APT prediction system and fine-tunes the training parameters (Milad et al., 2021).

The ML approach is also used to assist in decision-making for road maintenance during the winter season. Since the thermal environment is complex in winter conditions, the prediction result for the pavement temperature should be a probability distribution instead of a single value. The author developed two different ML models in this case: BSTS and BNN. The BNN module shows a significant relationship between the two factors of slippery index and pavement surface condition and pavement surface temperature at 0°C. On the other hand, the BSTS algorithm consists of four sections: the local linear trend, seasonal component, regression component, and uncertainty of pavement surface temperature. The regression component shows a significant importance section for the BSTS module compared to the rest of the sections (Li et al., 2022). In the latest work, the author developed a hybrid model of finite element modeling with a machine learning algorithm to reduce the computational time required to conduct a parametric study. The studies examine the relationships between the pipe depth, temperature inlet, and length of the pipe to assess their impact on the thermal responses of the PSC. The findings reveal that, among the investigated inputs, the length of the pipe exerts the most significant impact on the outcomes. The research predicts that, over the course of a year, the heat

energy capacity can reach an impressive 1.17 GJ/m² with less than 2% error (Ghalandari, Hernando et al., 2023). On the other hand, a study excluded pipe design and only assessed these four parameters (water inlet temperature, water flow rate, solar radiation, and sun heat) using ANN, ANFIS, and LSSVM machine learning models for parametric studies. The result shows that the LSSVM had the best approach and predictability compared to the rest of the investigated ML because the modeling had less deviation compared to the experimental data (Ahmadi et al., 2020).

Therefore, ML algorithms significantly enhance experimental and numerical modeling by reducing computational costs and time through parametric studies. Besides that, ML helps the design engineer predict thermal performance and optimize systems in complex environments.

FUTURE DIRECTIONS

Future studies should focus on addressing the current dearth of comprehensive studies integrating machine learning into PSC research, particularly ones that encompass all essential inputs, such as pavement surface, sub-layers, the material composition of the pavement surface and sub-layers, pipe material, pipe design, pipe depth, airspeed on the pavement surface at various heights, pipe design and thickness, type of liquid, and the liquid's flow rate. In addition, researchers need to assess the mechanical properties and behavior of PSC subjected to a range of temperatures and moisture. There were studies by Curiosity Lab in Georgia and New York where they embedded solar panels and smart city sensors into paving to generate electricity to power electric car charging ports. These pilot projects are expected to expand to prove that this technology is reliable and able to support the growth of electric vehicles (Skip, 2020).

Apart from converting solar to electrical energy, recent studies show a growing trend in solar harness technologies like the photovoltaic cells being used for hydrogen production (solar to hydrogen). Since the current energy production is insufficient, researchers are seeking alternative eco-friendly energy at a lower cost. A study shows that the level cost of energy (LCOE) of using solar to hydrogen system brings less than \$2/kWh at the optimal conditions, with PV output reaching 100W while reducing carbon emission by up to 13% (Shboul et al., 2024). Further, a study hybrid on the spiral fluid solar photovoltaic thermal collector (SPVTC) with small-scale Hoffman's electrocatalytic hydrogen production cell (EHPC) improves the electrical power and hydrogen productivity of PV and EHPC by investigating the cooling fluid (water and air) at different flow rates. The results show an improvement in hydrogen daily production from 3.07 kg_{H₂}/d to 3.24–4.41 kg_{H₂}/d, while the electricity productivity increased from 69.45 kWh/d to 92.45 kWh/d–74.77 kWh/d. Economic analysis shows that the optimized system of PV-EHPC results in lower hydrogen production costs by 7.04% to 32.10% (El-Hadary et al., 2023). On the other

hand, the performance of PVTC-EHP for hydrogen production can be predicted by using artificial intelligence modeling consisting of vector functional links and mayfly optimizers. The modeling helps the author enhance its prediction accuracy and optimize the system performance, resulting in more reliable and validated results (Elaziz et al., 2021). This system also contributes to the sustainable development goals by promoting green energy solutions.

Utilizing the technology for hydrogen production adds beneficial value in terms of economic, environmental and social perspectives to the current solar energy harnessing technology.

CHALLENGES AND LIMITATION

The implementation of pavement solar collectors (PSC) and other solar energy systems presents several challenges and limitations that need to be addressed for successful adoption. Three points of view needed to be looked into: structural integrity, heat transfer efficiency, and economic feasibility. The PSC system for road pavement faces challenges in managing heavy traffic, affecting the pavement's load-bearing capacity. Additionally, the high costs associated with installing solar energy harnessing systems and ongoing maintenance present significant limitations, especially during the initial stages. Effective implementation requires specific locations and substantial subsidies or incentives to accelerate the adoption of these technologies. Given their expense, it is essential to enhance the efficiency of current solar energy systems to maximize energy capture within a limited area.

CONCLUSION

Researchers across engineering fields have widely investigated solar energy harvesting technology for a sustainable future. The implementation of Pavement Solar Collectors (PSC) systems in big cities leads to clean energy harvesting, improving pavement service life, and mitigating the urban heat island (UHI) effect. Based on the literature on PSC systems, the following main conclusion can be drawn:

1. The PSC system transforms a considerable amount of radiant energy from solar energy into heat and utilizes it. This approach is among the most widely used and implemented techniques for renewable energy sources, as it has industrialized to the furthest degree. It is possible to implement the studied system, and it has significant potential to emerge as a prominent energy source, further reducing reliance on fossil fuels. Solar collector pavement technology uses photovoltaics or photothermal transduction agents (PTAs) for solar energy conversion, enabling electricity or thermal power generation.
2. Compared to the other parameters investigated, the length of the pipe and inlet water temperature most influence the temperature outlet of the PSC system. In addition, the

serpentine pipe design at 50 mm in depth produced the highest outlet temperature, showing that this configuration had the most effective heat absorption from the pavement surface to the buried pipe. However, it's crucial to balance thermal efficiency with structural integrity, as pipes placed too close to the surface can compromise the pavement's load-bearing capacity.

3. Future work on this technology was seen to develop an efficient multi-functional renewable energy system, which is hydrogen production powered by solar power. The integration of electrolytic hydrogen production cells (EHP) with the photovoltaic (PV) system showcases a sustainable method of generating hydrogen, a green energy to meet the world's energy demand.

ACKNOWLEDGMENTS

The authors convey their gratitude to the Ministry of Higher Education Malaysia for the generous sponsorship of the research under the FRGS research grant FRGS/1/2020/TK0/UNITEN/02/18. This research was funded by the Dato' Low Tuck Kwong International Grant (20238002DLTK), the Higher Institution Centre of Excellence (HICoE), Ministry of Higher Education (MOHE), Malaysia under the project code 2024001HICOE as referenced in JPT(BPKI)1000/016/018/34(5), and the BOLD Refresh Postdoctoral Fellowships under Grant J510050002-IC-6 BOLDREFRESH2023-Centre of Excellence. Special thanks to the IRMC of Universiti Tenaga Nasional for the full cooperation given to make this project achievable.

REFERENCES

- Abbas, F. A., & Alhamdo, M. H. (2024). Experimental and numerical analysis of an asphalt solar collector with a conductive asphalt mixture. *Energy Reports*, *11*, 327–341. <https://doi.org/10.1016/j.egy.2023.11.065>
- Abo-Hashema, M. A. (2013). Modeling pavement temperature prediction using artificial neural networks. *Airfield and Highway Pavement 2013*, 490–505. <https://doi.org/10.1061/9780784413005.039>
- Ahmad, M., Itam, Z., Beddu, S., Alanimi, F. B. I., & Soanathan, S. A. P. (2018). A determination of solar heat collection in serpentine copper and rubber pipe embedded in asphalt pavement using finite element method. *Journal of Engineering and Applied Sciences*, *13*(1), 181–189. <https://doi.org/10.3923/jeasci.2018.181.189>
- Ahmadi, M. H., Baghban, A., Sadeghzadeh, M., Zamen, M., Mosavi, A., Shamshirband, S., Kumar, R., & Mohammadi-Khanaposhtani, M. (2020). Evaluation of electrical efficiency of photovoltaic thermal solar collector. *Engineering Applications of Computational Fluid Mechanics*, *14*(1), 545–565. <https://doi.org/10.1080/19942060.2020.1734094>
- Al-Manea, A., Al-Rbaihat, R., Kadhim, H. T., Alahmer, A., Yusaf, T., & Egab, K. (2022). Experimental and numerical study to develop TRNSYS model for an active flat plate solar collector with an internally serpentine tube receiver. *International Journal of Thermofluids*, *15*, Article 100189. <https://doi.org/10.1016/j.ijft.2022.100189>

- Alim, M. A., Tao, Z., Abden, M. J., Rahman, A., & Samali, B. (2020). Improving performance of solar roof tiles by incorporating phase change material. *Solar Energy*, 207, 1308–1320. <https://doi.org/10.1016/j.solener.2020.07.053>
- Beddu, S., Talib, S. H. A., & Itam, Z. (2016). The potential of heat collection from solar radiation in asphalt solar collectors in Malaysia. In *IOP Conference Series: Earth and Environmental Science* (Vol. 32, No. 1, p. 012045). IOP Publishing. <https://doi.org/10.1088/1755-1315/32/1/012045>
- Bhan, C., Verma, L., & Singh, J. (2020). Alternative fuels for sustainable development. In *Environmental Concerns and Sustainable Development* (pp. 317–331). Springer. https://doi.org/10.1007/978-981-13-5889-0_16
- Carrasco, J. M., Franquelo, L. G., Bialasiewicz, J. T., Galvan, E., PortilloGuisado, R. C., Prats, M. A. M., Leon, J. I., & Moreno-Alfonso, N. (2006). Power-electronic systems for the grid integration of renewable energy sources: A survey. *IEEE Transactions on Industrial Electronics*, 53(4), 1002–1016. <https://doi.org/10.1109/TIE.2006.878356>
- Dezfooli, A. S., Nejad, F. M., Zakeri, H., & Kazemifard, S. (2017). Solar pavement: A new emerging technology. *Solar Energy*, 149, 272–284. <https://doi.org/10.1016/j.solener.2017.04.016>
- Elaziz, M. A., Senthilraja, S., Zayed, M. E., Elsheikh, A. H., Mostafa, R. R., & Lu, S. (2021). A new random vector functional link integrated with mayfly optimization algorithm for performance prediction of solar photovoltaic thermal collector combined with electrolytic hydrogen production system. *Applied Thermal Engineering*, 193, Article 117055. <https://doi.org/10.1016/j.applthermaleng.2021.117055>
- El-Hadary, M. I., Senthilraja, S., & Zayed, M. E. (2023). A hybrid system coupling spiral type solar photovoltaic thermal collector and electrocatalytic hydrogen production cell: Experimental investigation and numerical modeling. *Process Safety and Environmental Protection*, 170, 1101–1120. <https://doi.org/10.1016/j.psep.2022.12.079>
- Esposito, L., & Romagnoli, G. (2023). Overview of policy and market dynamics for the deployment of renewable energy sources in Italy: Current status and future prospects. *Heliyon*, 9(7), Article e17406. <https://doi.org/10.1016/j.heliyon.2023.e17406>
- Ferreira, A. C., Silva, J., Teixeira, S., Teixeira, J. C., & Nebra, S. A. (2020). Assessment of the stirling engine performance comparing two renewable energy sources: Solar energy and biomass. *Renewable Energy*, 154, 581–597. <https://doi.org/10.1016/j.renene.2020.03.020>
- Finn, J., Leitte, A., Fabisch, M., & Henninger, S. (2021). Analysing the efficiency of solar roads within settlement areas in Germany. *Urban Climate*, 38, Article 100894. <https://doi.org/10.1016/j.uclim.2021.100894>
- Garg, A., & Saini, R. P. (2018). Study on design of cavity receiver of concentrating solar power plants - A review. In L. Chandra & A. Dixit (Eds.), *Concentrated Solar Thermal Energy Technologies: Recent Trends and Applications* (pp. 69–77). Springer. https://doi.org/10.1007/978-981-10-4576-9_7
- Ghalandari, T., Hernando, D., Hasheminejad, N., Moenielal, M., & Vuye, C. (2023). Lessons learnt from thermo-mechanical feasibility assessment of pavement solar collectors using a FE-ANN approach. *Case Studies in Construction Materials*, 19, Article e02582. <https://doi.org/10.1016/j.cscm.2023.e02582>
- Ghalandari, T., Shi, L., Sadeghi-Khanegah, F., Van den bergh, W., & Vuye, C. (2023). Utilizing artificial neural networks to predict the asphalt pavement profile temperature in western Europe. *Case Studies in Construction Materials*, 18, Article e02130. <https://doi.org/10.1016/j.cscm.2023.e02130>

- Gonçalves, W. D. G., Caspers, C., Dupont, J., & Migowski, P. (2020). Ionic liquids for thermoelectrochemical energy generation. *Current Opinion in Green and Sustainable Chemistry*, 26, Article 100404. <https://doi.org/10.1016/j.cogsc.2020.100404>
- Gong, J., Li, C., & Wasielewski, M. R. (2019). Advances in solar energy conversion. *Chemical Society Reviews*, 48(7), 1862–1864. <https://doi.org/10.1039/C9CS90020A>
- Guldentops, G., Nejad, A. M., Vuye, C., Van den bergh, W., & Rahbar, N. (2016). Performance of a pavement solar energy collector: Model development and validation. *Applied Energy*, 163, 180–189. <https://doi.org/10.1016/j.apenergy.2015.11.010>
- Hayat, M. B., Ali, D., Monyake, K. C., Alagha, L., & Ahmed, N. (2019). Solar energy - A look into power generation, challenges, and a solar-powered future. *International Journal of Energy Research*, 43(3), 1049–1067. <https://doi.org/10.1002/er.4252>
- Homadi, A., Hall, T., & Whitman, L. (2020). Using solar energy to generate power through a solar wall. *Journal of King Saud University - Engineering Sciences*, 32(7), 470–477. <https://doi.org/10.1016/j.jksues.2020.03.003>
- Hu, H., Vizzari, D., Zha, X., & Mantalovas, K. (2023). A comparison of solar and conventional pavements via life cycle assessment. *Transportation Research Part D: Transport and Environment*, 119, Article 103750. <https://doi.org/10.1016/j.trd.2023.103750>
- Huang, Y., Molavi Nojumi, M., Hashemian, L., & Bayat, A. (2023). Evaluation of a machine learning approach for temperature prediction in pavement base and subgrade layers in Alberta, Canada. *Journal of Transportation Engineering, Part B: Pavements*, 149(1), Article 04022076. <https://doi.org/10.1061/JPEODX.PVENG-1010>
- Johnsson, J., & Adl-Zarrabi, B. (2020). A numerical and experimental study of a pavement solar collector for the northern hemisphere. *Applied Energy*, 260, Article 114286. <https://doi.org/10.1016/j.apenergy.2019.114286>
- Kabir, E., Kumar, P., Kumar, S., Adelodun, A. A., & Kim, K. H. (2018). Solar energy: Potential and future prospects. *Renewable and Sustainable Energy Reviews*, 82, 894–900. <https://doi.org/10.1016/j.rser.2017.09.094>
- Kalidasan, B., Hassan, M. A., Pandey, A. K., & Chinnasamy, S. (2023). Linear cavity solar receivers: A review. *Applied Thermal Engineering*, 221, Article 119815. <https://doi.org/10.1016/j.applthermaleng.2022.119815>
- Kalidasan, B., Pandey, A. K., Shahabuddin, S., Samykano, M. M. T., & Saidur, R. (2020). Phase change materials integrated solar thermal energy systems: Global trends and current practices in experimental approaches. *Journal of Energy Storage*, 27, Article 101118. <https://doi.org/10.1016/j.est.2019.101118>
- Kehagia, F., Mirabella, S., & Psomopoulos, C. S. (2019). Solar pavement: A new source of energy. In *Bituminous Mixtures and Pavements VII* (pp. 441–447). CRC Press. <https://doi.org/10.1201/9781351063265-61>
- Kim, J., Lee, S. T., Yang, S., & Lee, J. (2017). Implementation of thermal-energy-harvesting technology on pavement. *Journal of Testing and Evaluation*, 45(2), Article 20140396. <https://doi.org/10.1520/JTE20140396>
- Li, Y., Chen, J., Dan, H., & Wang, H. (2022). Probability prediction of pavement surface low temperature in winter based on bayesian structural time series and neural network. *Cold Regions Science and Technology*, 194, Article 103434. <https://doi.org/10.1016/j.coldregions.2021.103434>

- Ma, T., Yang, H., Gu, W., Li, Z., & Yan, S. (2019). Development of walkable photovoltaic floor tiles used for pavement. *Energy Conversion and Management*, 183, 764–771. <https://doi.org/10.1016/j.enconman.2019.01.035>
- Masoumi, A. P., Tajalli-Ardekani, E., & Golneshan, A. A. (2020). Investigation on performance of an asphalt solar collector: CFD analysis, experimental validation and neural network modeling. *Solar Energy*, 207, 703–719. <https://doi.org/10.1016/j.solener.2020.06.045>
- Milad, A., Adwan, I., Majeed, S. A., Yusoff, N. I. M., Al-Ansari, N., & Yaseen, Z. M. (2021). Emerging technologies of deep learning models development for pavement temperature prediction. *IEEE Access*, 9, 23840–23849. <https://doi.org/10.1109/ACCESS.2021.3056568>
- Nojumi, M. M., Huang, Y., Hashemian, L., & Bayat, A. (2022). Application of machine learning for temperature prediction in a test road in Alberta. *International Journal of Pavement Research and Technology*, 15(2), 303–319. <https://doi.org/10.1007/s42947-021-00023-3>
- Nakayama, Y. (2018). Chapter 6 - Flow of viscous fluid. In Y. Nakayama (Ed.), *Introduction to Fluid Mechanics (2nd ed.)* (pp. 99–133). Butterworth-Heinemann. <https://doi.org/https://doi.org/10.1016/B978-0-08-102437-9.00006-1>
- Nasir, D. S. N. M., Hughes, B. R., & Calautit, J. K. (2015). A study of the impact of building geometry on the thermal performance of road pavement solar collectors. *Energy*, 93, 2614–2630. <https://doi.org/10.1016/j.energy.2015.09.128>
- Owusu, P. A., & Asumadu-Sarkodie, S. (2016). A review of renewable energy sources, sustainability issues and climate change mitigation. *Cogent Engineering*, 3(1), Article 1167990. <https://doi.org/10.1080/23311916.2016.1167990>
- Primc, K., Dominko, M., & Slabe-Erker, R. (2021). 30 years of energy and fuel poverty research: A retrospective analysis and future trends. *Journal of Cleaner Production*, 301, Article 127003. <https://doi.org/10.1016/j.jclepro.2021.127003>
- Ryms, M., Denda, H., & Jaskuła, P. (2017). Thermal stabilization and permanent deformation resistance of LWA/PCM-modified asphalt road surfaces. *Construction and Building Materials*, 142, 328–341. <https://doi.org/10.1016/j.conbuildmat.2017.03.050>
- Saha, K., & Frøyen, Y. (2021). An automated approach to facilitate rooftop solar PV installation in smart cities: A comparative study between Bhopal, India and Trondheim, Norway. In P. Sharma (Ed.), *Geospatial Technology and Smart Cities: ICT, Geoscience Modeling, GIS and Remote Sensing* (pp. 75–92). Springer. https://doi.org/10.1007/978-3-030-71945-6_5
- Statista. (2021). *Length of Completed Main Paved Roads in Saudi Arabia from 2010 to 2019*. <https://www.statista.com/statistics/628720/saudi-arabia-total-length-of-main-paved-roads-completed/#statisticContainer>
- Shboul, B., Zayed, M. E., Tariq, R., Ashraf, W. M., Odat, A. S., Rehman, S., Abdelrazik, A. S., & Krzywanski, J. (2024). New hybrid photovoltaic-fuel cell system for green hydrogen and power production: Performance optimization assisted with Gaussian process regression method. *International Journal of Hydrogen Energy*, 59, 1214–1229. <https://doi.org/10.1016/j.ijhydene.2024.02.087>
- Skip, D. (2020). *High-Tech Roads Are Powering Electric Cars, Sensors and More*. Government Technology. <https://www.govtech.com/fs/high-tech-roads-are-powering-electric-cars-sensors-and-more.html>

- Talib, S. H. A., Hashim, S. I. N. S., Beddu, S., Maidin, A. F., & Abustan, M. S. (2017). Heat lump in different pavement layer using ethylene glycol as a solar heat collector. In *MATEC Web of Conferences* (Vol. 87, p. 01015). EDP Sciences. <https://doi.org/10.1051/mateconf/20178701015>
- The World Bank Group. (2021). *Climatology*. <https://climateknowledgeportal.worldbank.org/country/saudi-arabia/climate-data-historical>
- Todd, D. A. (2011). *Asphalt Pavement Solar Collectors: The Future is Now*. Buildipedia. <http://buildipedia.com/aec-pros/engineering-news/asphalt-pavement-solar-collectors-the-future-is-now?print=1&tmpl=component>
- Tyagi, V. V., Pathak, S. K., Chopra, K., Saxena, A., Kalidasan B., Dwivedi, A., Goel, V., Sharma, R. K., Agrawal, R., Kandil, A. A., Awad, M. M., Kothari, R., & Pandey, A. K. (2024). Sustainable growth of solar drying technologies: Advancing the use of thermal energy storage for domestic and industrial applications. *Journal of Energy Storage*, 99, Article 113320. <https://doi.org/10.1016/j.est.2024.113320>
- van Bijsterveld, W. T., Houben, L. J. M., Scarpas, A., & Molenaar, A. A. A. (2001). Using pavement as solar collector: Effect on pavement temperature and structural response. *Transportation Research Record: Journal of the Transportation Research Board*, 1778(1), 140–148. <https://doi.org/10.3141/1778-17>
- Vinod, Kumar, R., & Singh, S. K. (2018). Solar photovoltaic modeling and simulation: As a renewable energy solution. *Energy Reports*, 4, 701–712. <https://doi.org/10.1016/j.egy.2018.09.008>
- Xu, L., Wang, J., Xiao, F., El-Badawy, S., & Awed, A. (2021). Potential strategies to mitigate the heat island impacts of highway pavement on megacities with considerations of energy uses. *Applied Energy*, 281, Article 116077. <https://doi.org/10.1016/j.apenergy.2020.116077>
- Yang, L., Jiang, J., Liu, T., Li, Y., Zhou, Y., & Gao, X. (2018). Projections of future changes in solar radiation in China based on CMIP5 climate models. *Global Energy Interconnection*, 1(4), 452–459. <https://doi.org/10.14171/j.2096-5117.gei.2018.04.005>
- Yoro, K. O., & Daramola, M. O. (2020). CO₂ emission sources, greenhouse gases, and the global warming effect. In *Advances in Carbon Capture* (pp. 3–28). Elsevier. <https://doi.org/10.1016/B978-0-12-819657-1.00001-3>
- Zaim, E. H., Farzan, H., & Ameri, M. (2020). Assessment of pipe configurations on heat dynamics and performance of pavement solar collectors: An experimental and numerical study. *Sustainable Energy Technologies and Assessments*, 37, Article 100635. <https://doi.org/10.1016/j.seta.2020.100635>
- Zhou, B., Pei, J., Nasir, D. M., & Zhang, J. (2021). A review on solar pavement and photovoltaic/thermal (PV/T) system. *Transportation Research Part D: Transport and Environment*, 93, Article 102753. <https://doi.org/10.1016/j.trd.2021.102753>
- Zhou, B., Pei, J., Hughes, B. R., Nasir, D. S. N. M., Vital, B., Pantua, C. A. J., Calautit, J., & Zhang, J. (2021). Structural response analysis of road pavement solar collector (RPSC) with serpentine heat pipes under validated temperature field. *Construction and Building Materials*, 268, Article 121110. <https://doi.org/10.1016/j.conbuildmat.2020.121110>

